



# POWER PACK - AIR COOLED

PREMIUM - 2 PUMP - 2,300 BTUs

- Engineered by beer-industry experts for performance and value.
- Digital thermostat for accurate glycol bath temperature.
- Expanded urethane foam insulates cabinet to maintain glycol temperature and minimize condensation.
- Exterior sight glass to verify glycol bath level.
- Anti-vibration pads reduce motor noise.
- Rugged stainless steel cabinet.



**MMPP4301-PKG**

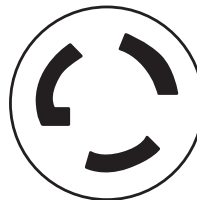

**L5-30P**



# SPECIFICATIONS

Micro Matic reserves the right to change specifications without notice.



PART NO.	DESCRIPTION	SHIPPING WEIGHT
MMPP4301-PKG	Air cooled power pack, 2 pump and motor, equipped with Smart Draft™	58 kg
		128 lbs

## OPERATING PERFORMANCE

COMPRESSOR	1/3 HP
BTU PER HOUR	2,300
PLUG TYPE (NEMA #)	L5-30P
CORD LENGTH	8'
VOLTAGE	115
RUNNING	17.7A

REFRIGERANT	R513a*
CHARGE	0.34 kg (12 oz)
REFRIGERANT RUNNING PRESSURE	18 (low) 140 (high)
BATH CAPACITY	43.5 litre (11.5 gallons)
PUMP TYPE	Rotary Vane
PUSH IN CONNECTOR	12.7mm (1/2") O.D.

Beginning January 2023: Charged with R513a refrigerant  
 Prior to January 2023: Charged with R134a refrigerant

## DIMENSIONS

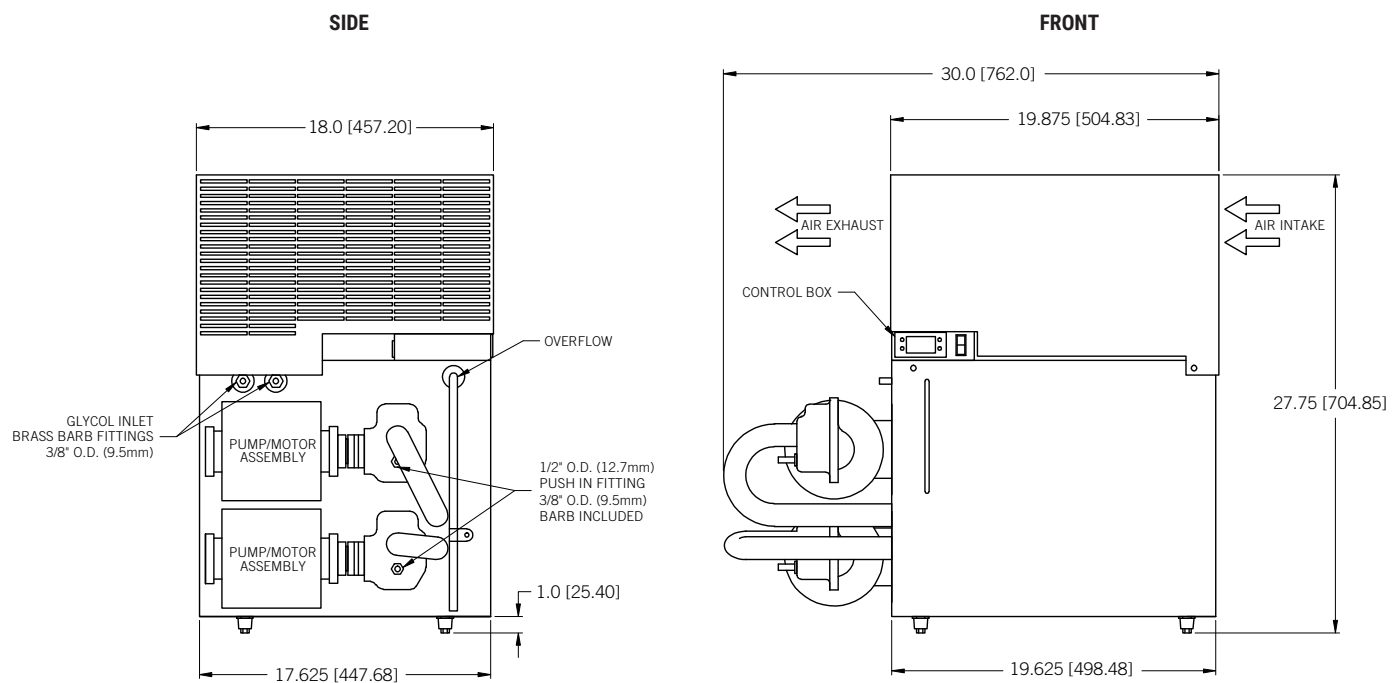

Toll-Free: 1-866-327-4159  
[www.micromatic.com](http://www.micromatic.com)

**West**  
 19791 Bahama St.  
 Northridge, CA 91324  
 Tel. (818) 701-9765  
 Fax. (818) 701-9844

**Central**  
 10726 North Second St.  
 Machesney Park, IL 61115  
 Tel. (815) 968-7557  
 Fax. (815) 968-0363

**Southeast**  
 15111 Dispense Ln.  
 Brooksville, FL 34604  
 Tel. (352) 799-6331  
 Fax. (352) 796-2429

**Northeast**  
 4601 Saucon Creek Rd.  
 Center Valley, PA 18034  
 Tel. (610) 625-4464  
 Fax. (610) 625-4466